



Dream of Museum
DMUSEUM Inc.

Product catalog 2024

🏠 www.DMuseum.net

☎ +82 31-548-2830

✉ info@dmuseum.net

Motorized smart lighting

DL-18

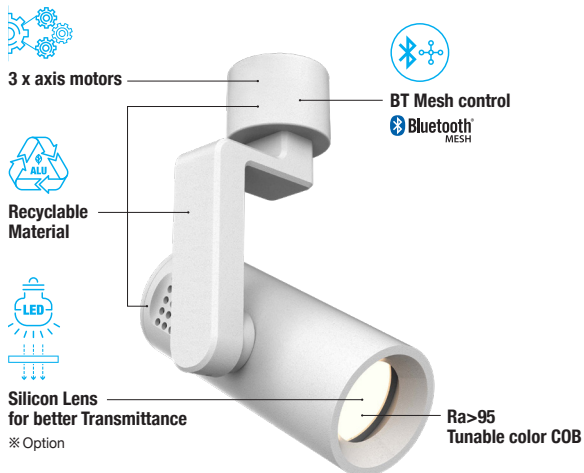
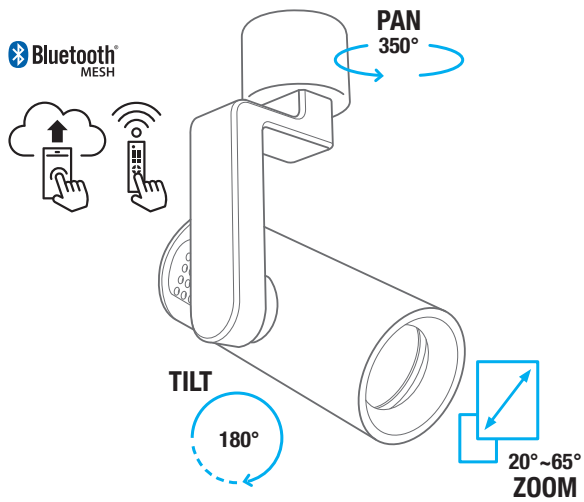

Size	Luminous flux	Input	Output	LED
230 X 203 X 63ø	1500lm	AC 110-220V	18W	Bridgelux COB ※ Option
Pan & Tilt	Track	Beam angle	Color Temperature	Body color
350°&180°	3 Phase (Global Trac, Power gear compatible)	20° ~ 65°	2700K~ 6500K	Black & White

Features

Tunable color

The most important function of exhibit lighting is to adjust the light to a color temperature that best represents the true color of the exhibit. With wireless control technology, the DL-20 can control color temperatures from 2700K to 6500K with a single fixture. It reproduces the natural spectrum of natural light, from a warm and vibrant experience to an excellent color rendering with a CRI>95.

Color Temperature	2700K~6500K
Bridgelux COB	Ra > 95

“You can select the light source according to your object and artwork.”
* CREE, OSRAM, SAMSUNG etc.

Motor & Gearbox

The motors(3x) are integrated into the fixture for precise angle adjustment and focal length. You can also freely design and position the light anywhere on the ceiling or wall. In addition, a special precision gearbox developed in-house enhances the durability of the fixture for long periods of time, and wireless control technology allows you to adjust pan, tilt, CCT, and zoom (beam angle).

Pan	350°
Tilt	180°
Zoom	20° ~ 65°

BT Mesh

DL-20 does everything you need it to do when there is a large distance between the ceiling or the subject to be illuminated, and the floor, making it useful in museum, exhibition spaces, as well as commercial spaces with high ceilings. You can group and control lights through a BT mesh network. Control rotation, tilt, color temperature, dimming, and more.

Bluetooth Mesh Network
Latest cutting edge technology BT Mesh 5.x (Up to 32,000 node per network)

Recyclable

By mounting the SMPS on an adapter that mates to the track, this is an economical design that is specific to exhibition spaces where the luminaire itself needs to be as invisible as possible. We also focused on sustainability by using aluminum for the exterior design, which is recyclable.

Aluminum is used not only for the body, but also for the arms and head.
The use of plastic has been minimized.



Total Solutions

We automate all lighting design, placement and field installation steps. Monitor design, deployment, health, and energy usage on cloud servers.

Application	Timer, Scenario setting
Dash_board	Design, Energy saving

And best of all, our smart lighting remembers and automatically manages the optimal lighting settings desired by artists and managers for each artwork and object.

Cloud Dashboard
Daylight Harvesting
Modules & Controllers

Individual control, group control and scenario settings of lights are possible via smart devices or traditional switch methods.

Lighting settings can be customized according to the open and closed times of the space, saving energy and easily managing the lifespan and operating hours of the light.

Scheduling and natural light harvesting features provide significant energy savings.

Smart Lighting Total Solutions

DMUSEUM's smart lighting integration solution is software that meets international standards and allows for grouping, individual control, and scenario setting of lights via a Bluetooth mesh network. We provide differentiated solutions from lighting planning, design, and lighting management to smart functional control systems.



Scheduling

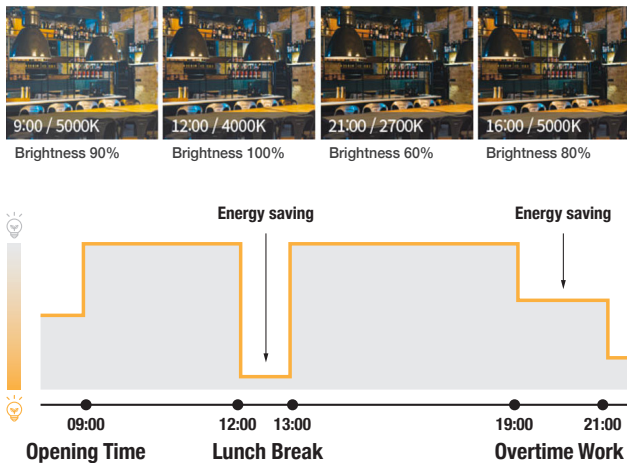



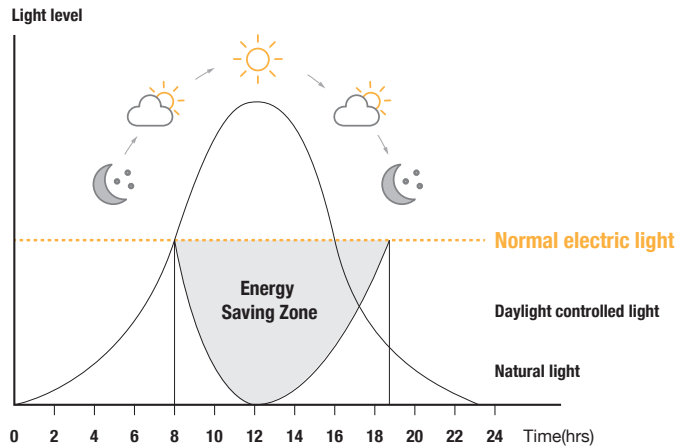



Daylight Harvesting



This is a technology that reduces energy consumption by automatically adjusting the brightness of lights according to the brightness of solar power at different times of the day.

We also offer a range of solutions to smartly control your lighting.

-  **BT module**
— Wireless communication module (BT SIG NLC up to 32,000)
-  **On/Off switch controller**
— BT Mesh On/Off relay switch
-  **Multi sensor**
— Motion, illumination, temperature & door-opening detection
-  **PWM controller**
— 5-48VDC, LED bar/module controller (RGBW, color temperature, dimming)
-  **Remote wheel**
— Remote control for color temperature / dimming control
-  **APP & cloud server**
— Smartphone, tablet, PC

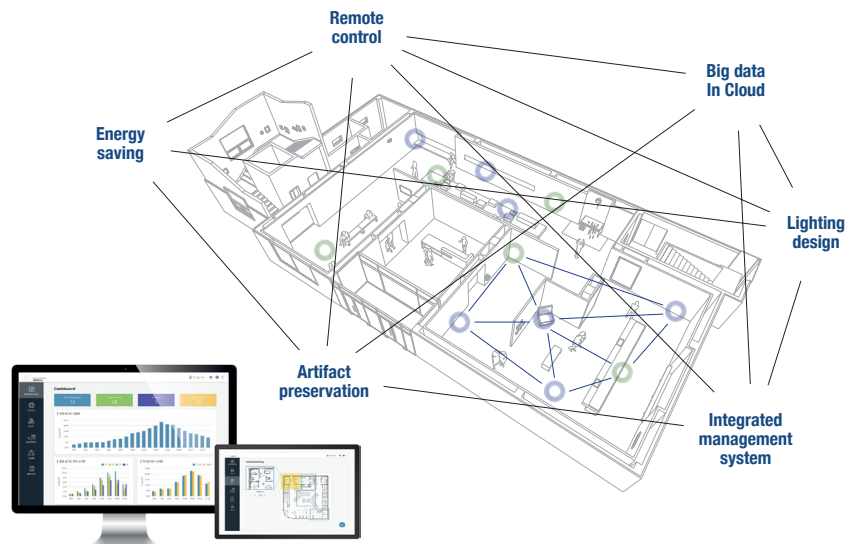



Contact us

www.DMuseum.net

Smart Lighting development
Exhibition Design
Media Content Production

Address

A-103, Giheung ICT Valley, 58-1, Giheung-ro,
Giheung-gu, Yongin-si, Gyeonggi-do,
Republic of Korea

Contact

Tel. +82-31-548-2830
info@dmuseum.net